

. 25 . Distribution System Automation

Introduction	25.1
Factors influencing the application of automation to distribution networks	25.2
Primary distribution system automation	25.3
Secondary distribution networks - urban areas	25.4
Secondary distribution networks - rural areas	25.5
Communications	25.6
Distribution system automation software tools	25.7

• 25 • *Distribution System*

Automation

25.1 INTRODUCTION

Distribution systems are generally considered to be supply networks operating at 132kV and below, and to which consumers are normally connected. Within a distribution system, a division into primary and secondary distribution systems is often made, with primary distribution systems having voltages above 22kV and secondary distribution systems voltage below this value.

Automation of distribution systems has existed for many years. The extent to which automation has been applied has been determined by a combination of technology and cost. For many years the available technology limited the application of automation to those parts of the distribution system where loss of supply had an impact on large numbers of consumers. Technology was not available to handle the large amount of geographically dispersed data required for automation of distribution systems in rural areas. Even when developments in technology began to overcome these problems, the cost of applying the technology was large in relation to the benefits gained. Often, there was no financial incentive to apply automation in rural distribution systems, and consumers were not entitled to compensation for loss of supply. As relatively few consumers would be affected by a fault on a rural distribution system, compared to a similar fault in an urban distribution system, the number of customer complaints received was not a sufficiently important factor to justify investment in network reliability. Interruptions to consumers in rural areas were treated as being inevitable.

Recent developments such as privatisation started to focus attention on the cost to the consumer of a loss in supply. Interruptions in supply began to be reflected in cost penalties (directly or indirectly) to the Utility, thus providing a financial incentive to improve matters. Rural consumers gradually became more aware of the disparity in the number of supply interruptions between rural and urban distribution networks. This led, in conjunction with an increasing emphasis on Power Quality issues (see

Chapter 23), to pressure on Utilities to improve the situation. In addition, the population in rural areas became more dependent on electrical equipment, and thus the consequences of a supply outage were more significant.

The term automation conjures up the use of microprocessors, maybe linked together over a communications network and running special purpose software to execute a sequence of actions automatically. While such technology is employed and forms part of distribution system automation, the term automation may imply nothing more than the ability to close or open a switch remotely in addition to local (hand) control. It may involve nothing more than the addition of an

actuator, and simple on/off remote control facilities. Technology has been applied to reduce the cost of such devices, thus improving the economics of their application. Therefore, the field of distribution system automation is a very broad one, and the solution applied to any particular problem will reflect the particular circumstances of problem and regulatory regime of the Utility concerned.

Figure 25.1 shows typical distribution systems that form the subject of this chapter, complete with the elements of the distribution system to which automation techniques are applied. The remaining sections of this chapter describe the various automation techniques available, together with typical applications.

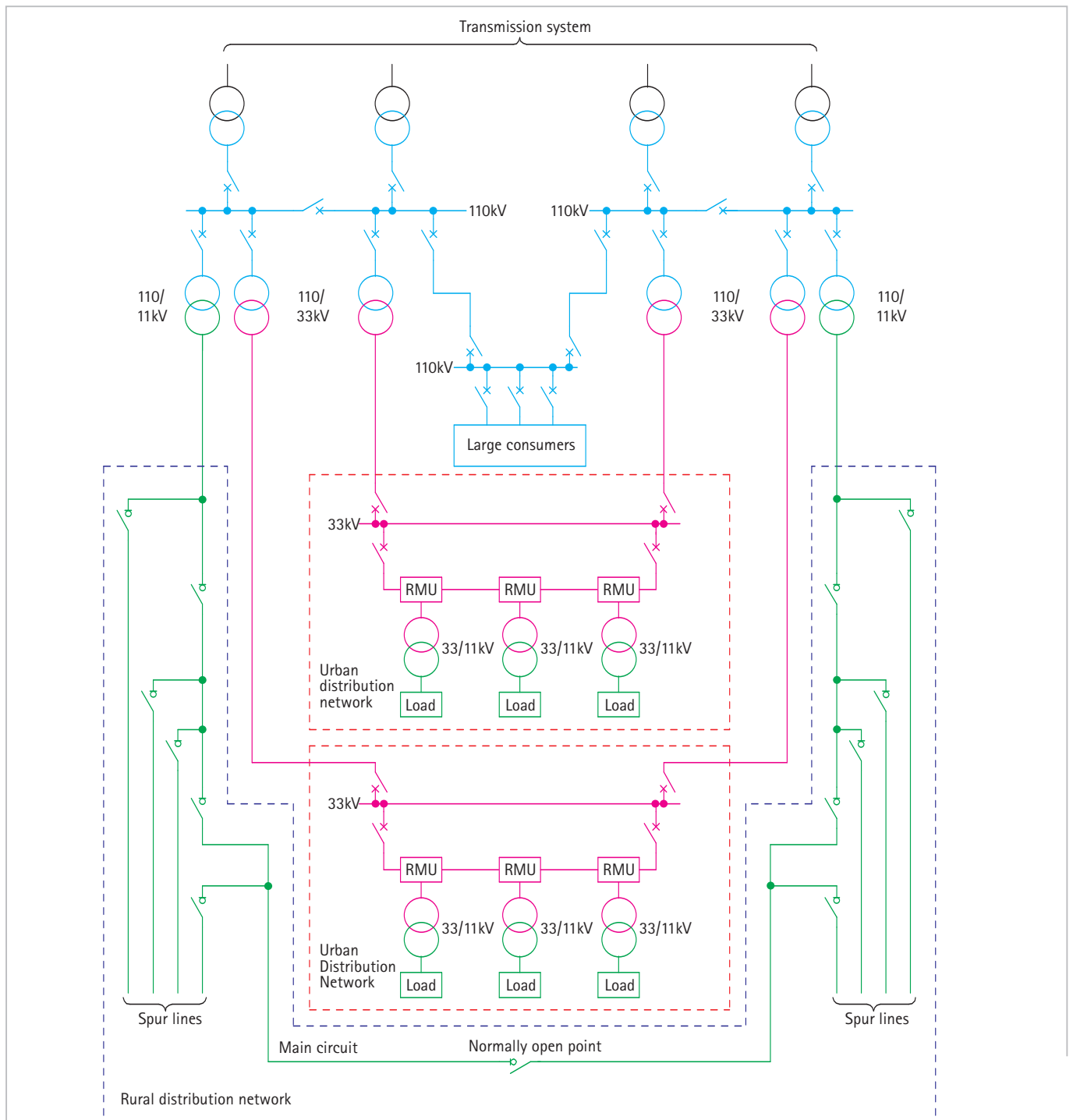

Figure 25.1: Elements of a distribution system

25.2 FACTORS INFLUENCING THE APPLICATION OF AUTOMATION TO DISTRIBUTION NETWORKS

Cost is the main driving factor in the application of an automation scheme to a distribution network. Regulatory pressure may also influence the decision. The cost may arise in many different ways. Savings from implementing distribution system automation result from reducing:

- a. revenue foregone during outages
- b. cost of handling customer complaints
- c. cost of control/maintenance staff
- d. cost of compensation to consumers for outages

Less tangible benefits can also be identified, such as deferral of system enhancement (i.e. deferral of capital expenditure) through better knowledge of network performance. The financial advantage to the Utility of such benefits may be more difficult to calculate, but should be incorporated in any financial comparison for a proposed scheme.

There are inevitably costs incurred through use of an automation scheme:

- a. cost of implementation (capital cost)
- b. cost of operation
- c. cost of maintenance

and clearly the total costs saved must be in excess of the total costs of implementation and use to make a scheme viable.

For many years, automation has been implemented at voltages above 22kV, simply due to the number of consumers inconvenienced by a supply outage and the resulting costs (in whatever form). However, in recent years, the traditional balance of cost/benefit has been changed, due to:

1. increasing dependence by communities/industry on electricity
2. privatisation (in some countries)
3. the spread of electricity supply to ever more remote areas
4. the cost of training and retaining skilled staff
5. increasing emphasis on Power Quality issues

This change has been in favour of increased automation of the distribution system, including system voltages down to LV. Regulatory pressure to improve the reliability and quality of electricity supply to end-users produces an outcome that the associated costs are only acceptable if technology is applied to automate the secondary distribution system. Therefore, automation of the secondary distribution system has become more

widespread. At the same time, overhead lines in rural areas suffer many more faults leading to consumer supply loss than urban cable networks. These findings are not surprising – rural distribution networks are commonly in the form of radial feeders whereas urban networks are often in the form of ring or meshed networks to minimise the chances of supply loss to large groups of consumers. Similarly, overhead lines are normally more prone to faults than underground cables. Because the fault incidence on EHV overhead lines is significantly lower than for those on distribution systems, it is also arguable that the technical standards relating to overhead lines on distribution networks also require review.

Therefore, developments in distribution system automation have concentrated largely on applications to the secondary distribution system.

25.3 PRIMARY DISTRIBUTION SYSTEM AUTOMATION

The primary distribution system is generally accepted as comprising those elements of the distribution system operating at voltages above 22kV. Distribution uses both cable and overhead lines, and the power levels involved will enable either a large group of domestic consumers, or several industrial plants to be served. Very large industrial plants may justify their own dedicated feeders from the primary distribution substation (Figure 25.2).

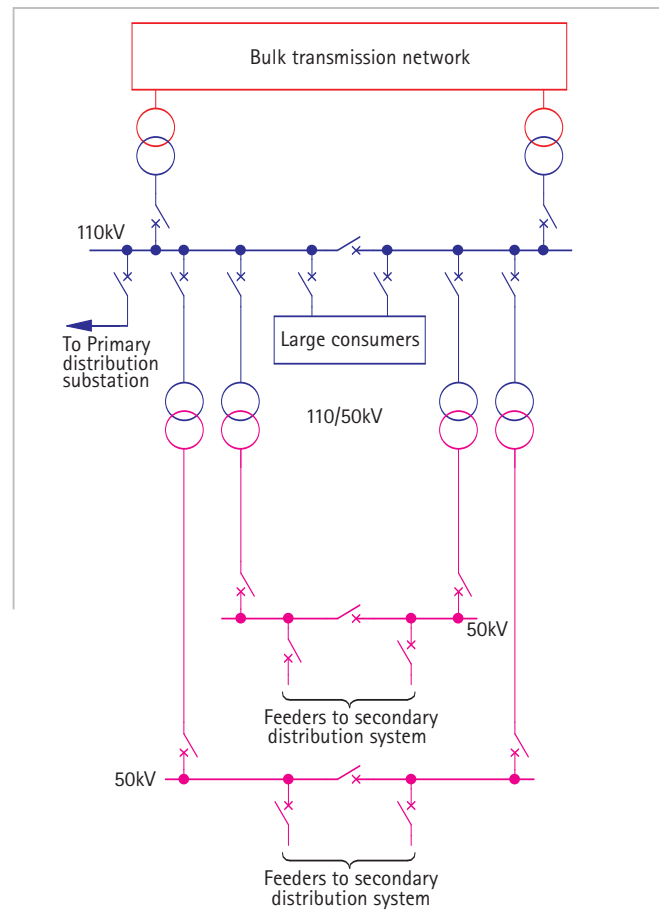

Figure 25.2: Primary distribution system

Automation of the primary distribution system is well established, due to the impact of supply loss on the many and diverse consumers that it serves. In addition, the distribution system is usually interconnected, so that loss of supply to consumers in the event of a circuit outage is minimised. The circuit breakers and protection systems used in the system will already be capable of remote control/monitoring. However, status information on a circuit may be confined to simple on/off/open/closed/tripped indications, and determination of the cause of a trip will still require despatch of a maintenance crew to the equipment concerned. Only after the cause of a trip has been determined can fault location and rectification take place.

Hence modern network automation techniques can be usefully applied. Application of such techniques brings the following advantages:

- a. ability to control a much larger area
- b. provision of detailed network performance information
- c. reduction in space requirements
- d. reduction in staffing

25.3.1 Control Area Size

The modern electric power network has tight coupling between the various elements - a problem in one area may have knock-on effects over a wide area. Hence, traditional distribution control rooms serving a limited geographical area are being replaced by fewer (perhaps only one for a Utility serving up to 10,000km² area) and in these cases older automation systems may not be able to handle the total I/O count. Either the upper limit on I/O points will have been reached, or response times to an event become too slow to be of practical use. Use of a modern automation system permits a reduction in the number of control centres used, with each centre able to oversee a much wider geographical area. Thus, incidents that have an impact outside of the immediate area can be dealt with more effectively and hence result in a better response to the incident and fewer customer complaints.

25.3.2 Detailed Network Performance Information

Modern microprocessor-based relays can store a wealth of information relating to the cause of a trip and transmit such data, when requested, to a Control Centre. Hence, the nature and possibly the location of a fault can be identified. The maintenance/repair crew can be provided with better information, thus shortening circuit downtime and enhancing distribution network availability. Data relating to network loading and

voltage variations can also be stored and downloaded at regular intervals and provides two main benefits. Firstly, monitoring of Power Quality can be undertaken and hence customer complaints readily investigated. Sufficient information may well be available to establish the short-term actions required to correct or minimise the problem, resulting in fewer customer complaints, and a possible reduction in financial penalties. Secondly, a review of the loading profile of circuits against time can be undertaken. Using appropriate plant thermal ageing models, the rating of circuits can be reviewed and adjusted. This may result in an enhanced rating being given to circuits, and hence the postponement of capital expenditure.

25.3.3 Space Requirements

Many countries have significant pressure on land-use for infrastructure requirements. A modern microprocessor relay can now undertake the functions previously requiring several discrete relays, and of measurement devices, thus eliminating numerous VT's and CT's, measurement transducers/indicators, auxiliary contacts on circuit breakers, etc. Wiring between plant items is much reduced. Use of modern communications techniques such as data transmission by mobile radio networks can similarly reduce wiring requirements to/from the Control Centre. The space requirements in a substation for housing the relays associated with the circuits of a distribution network can be reduced, giving a significant reduction in expenditure on the buildings associated with the substation. Benefits can also be obtained from eliminating separate metering devices, reducing space provision and hence cost.

25.3.4 Staffing Levels

The reduction in the number of Control Centres leads naturally to a reduction in the staffing requirement for such places. More importantly, the ability of intelligent relays to report their settings and measured values to a Control Centre, and to accept revised settings downloaded from the control centre can lead to significant improvements in the quality of supply, while at the same time reducing the staffing required compared to a manual system. Distribution systems are subject to regular changes in configuration and loading, and these may require changes to protection relay settings.

Manual means of determining protection relay settings involve site surveys at the substations concerned to record existing settings, followed by further visits to carry out changes as required. Pressures on staffing may mean that such exercises are carried out at extended intervals. A modern automated distribution system eliminates much of the manual effort by automation of

the reporting and downloading of relay settings. While scope still exists for introducing errors into relay setting values, the incidence of these is reduced. Regular comparison of settings against desired values increases the possibility of incorrect settings being identified and corrected, thus minimising the resulting disruption.

25.4 SECONDARY DISTRIBUTION NETWORKS - URBAN AREAS

A high level of interconnection, either ring or mesh, to ensure a high degree of availability of supply to the consumer, characterises secondary distribution networks in urban areas. Domestic, industrial and commercial consumers will suffer great inconvenience through only a relatively short loss in supply of only a few hours, with business likely to suffer considerable financial loss if an interruption is longer than 2-4 hours. For domestic consumers, loss of supply for between 4-8 hours is largely an inconvenience, though loss may result from spoilage of freezer contents, etc. and in cold weather may place vulnerable sections of the community at risk. Such hazards for a privatised Utility give rise to the potential for significant financial loss, through claims for compensation.

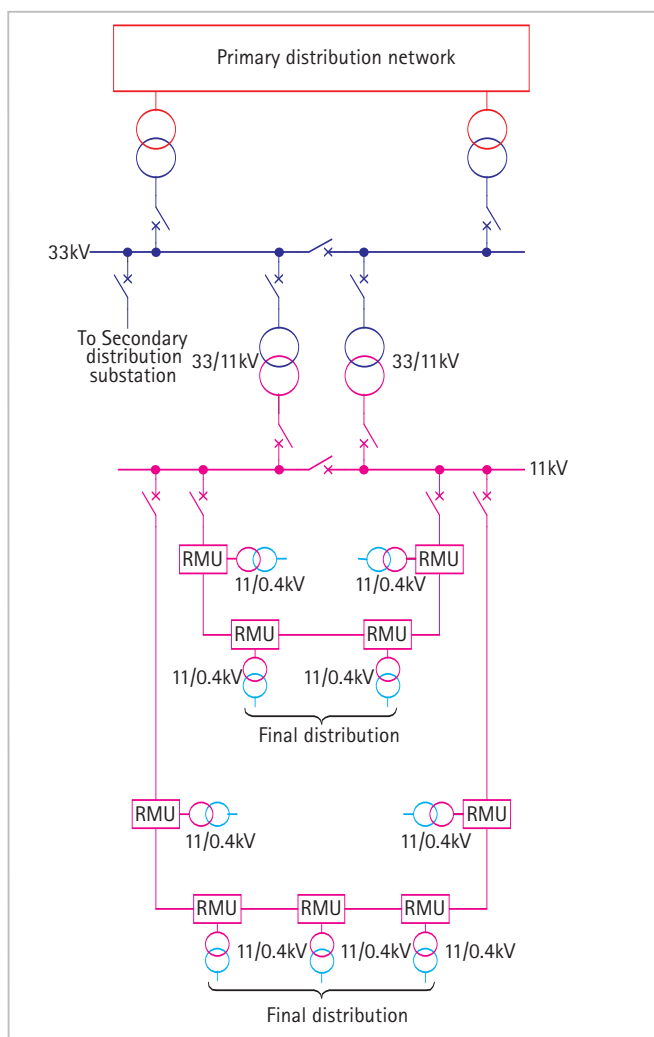

Figure 25.3: Typical urban secondary distribution system

A typical urban secondary distribution system is shown in Figure 25.3. There is a large proportion of underground cable, and final feeders to LV distribution substations take the form of feeders from Ring Main Units (RMU's). Several RMU's are connected in a loop fed from one or more substations, the loop normally being open at some point. The open point is normally chosen to equalise loading at both ends of the ring as far as possible. The cables forming the ring and all associated switchgear, etc., are sized for single-end feeding of the whole ring, to allow for an outage affecting the ring between a substation and the first RMU, or at the substation itself.

The arrangement of an individual RMU is shown in Figure 25.4(a). For many years, only local operation and indications (trip/healthy) were provided, so that switching operations required a visit from field staff. Trips at an RMU resulting in loss of supply to consumers were annunciated through customer complaints, no direct indication to the control room was provided.

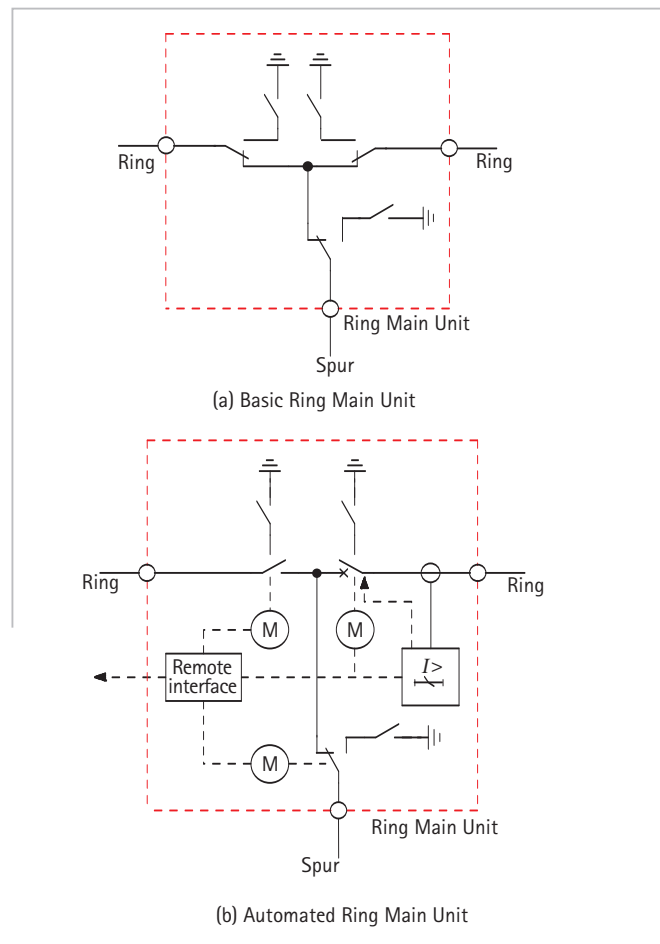

Figure 25.4: Ring Main Unit

The individual items of plant have developed over many years and are generally reliable, taken individually. Major failures of a complete distribution system are rare, and usually stem from inadequate specification of the original equipment, or failure to monitor the condition of

equipment with time. This is especially the case where loading and/or environmental conditions have changed. However, once a fault occurs (and sooner or later this is inevitable), location, repair and restoration of normal supply can take time. In particular, repair of faults in underground cables may take some time, as the location must first be identified to within a few metres, and then the ground excavated to effect the repair. In the centre of a large city, excavation is not popular and will be expensive. Traffic congestion will ensure that the response time for a repair crew to arrive at a substation after a fault has been reported is not trivial, especially where (in some privatised Utilities), penalties may be imposed for loss of supply to consumers lasting more than 60 minutes.

The application of automation techniques has therefore many advantages. This will usually require the provision of extra features to an RMU. The most common features added are:

- a. capability for remote operation – addition of actuators for open/close operation of the various devices that are capable of being operated from a remote location
- b. provision of remote indications of status of the various devices
- c. addition of Fault Passage Indicators (FPI's). An FPI is a sensor that detects passage of current in excess of a defined value, and therefore provides an indication that the fault is further from the supply point (for a radial-fed system) than the FPI
- d. addition of a protection relay for phase/earth faults

Note that once it has been decided to provide remote control or indication, some form of communications interface is also required and the incremental cost of providing both remote control and indication instead of one or the other is very small

A typical configuration for an RMU with all options fitted is shown in Figure 25.4(b).

Traditional manual operation of RMU's can be replaced by remote control. Many existing designs of RMU can be adapted in this way, while all new designs have this feature as standard. The remote communications feature provides the following features:

1. issuing of commands to open/close the circuit breaker, etc.
2. provision of status information (position, availability) etc.
3. voltage and current data

Provision of remote indication of status to a Control Centre enables the response time to a fault to be reduced. The reduction in customer complaints and

compensation paid can be justification in itself. Interrogation of relays/(FPI's) can then determine the feeder circuit on which the fault has occurred, thus enabling restoration of supply to customers unaffected by the fault to begin immediately. In some cases, it may be possible to devise automatic sequences for this, thus relieving the control room operator of this duty and enabling concentration on the task of precise fault location and repair.

Equipment that is used rarely may fail to operate when called upon to do so. Much effort has been paid in protection relay design to avoid this problem, and digital and numerical relays generally have a self-checking function that runs regularly and is arranged to alarm if the function detects an internal fault. However, circuit breakers and other switching devices that may not operate for a considerable period can get stuck in their normal position and thus fail to operate when commanded to. A number of major system collapses have been known to occur because of such problems, it being not always possible to provide backup protection that will operate in sufficient time. One solution to this problem is to exercise such equipment on a regular basis. This can be done at little cost to the Utility if carried out remotely, but is prohibitively expensive if carried out on a local manual basis. Finally, through an improved knowledge of network performance, network enhancements may be able to be postponed or eliminated, which is a substantial bonus as the costs of installing new cables in urban areas can be very high. Figure 25.5 shows a modern RMU suitable for installation indoors – practice varies between countries in such matters, with outdoor installation also being common.



Figure 25.5: Modern indoor RMU

25.5 SECONDARY DISTRIBUTION NETWORKS - RURAL AREAS

The challenges in network automation for rural areas are similar to those in urban areas, however the network topology may be very different.

A typical conventional network topology is shown in Figure 25.6. Due to relatively sparse population, feeders are generally radial, often with spur lines, and can be quite lengthy – 60km length of main feeder at 11kV being possible. The feeders are usually conventional overhead lines with uninsulated conductors, and fault rates for these lines are high in comparison with cables or EHV overhead lines. In some countries, lightly insulated conductors are used, and these reduce the fault rates experienced.

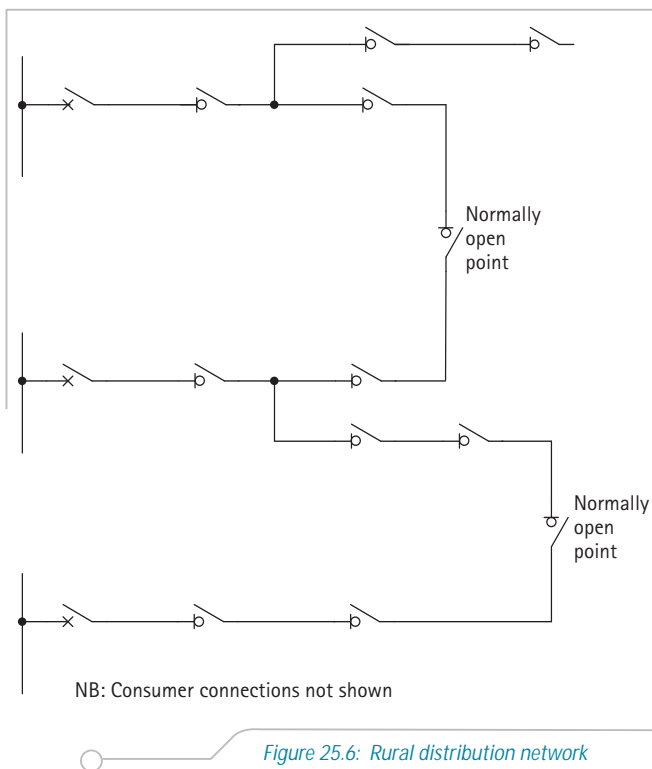

Figure 25.6: Rural distribution network

Response times for location and repair of faults may be lengthy, as the only indication of a fault having occurred may be customer complaints of loss of supply due to the source circuit breaker having tripped. In this case, all consumers fed by the line will suffer loss of supply, and determining the location of the fault may take a considerable time.

Many possible enhancements taking advantage of automation techniques to the basic feeder topology are possible to improve the situation:

- add remote control/monitoring to the circuit breaker
- add automatic sectionalisers

25.5.1 Circuit Breaker Remote Control/Monitoring

This provides a small advantage in alerting the operator to a loss of supply, and a larger one in minimising restoration time. Most OHL faults are transient in nature, and therefore circuit breaker reclosure after a short time interval is likely to result in supply being restored. The operator may therefore attempt a manual closure of the circuit breaker to restore supply. Use of an auto-reclose scheme (see Chapter 14) may further reduce the disconnection time and relieve the control room operator of workload, especially in conditions of poor weather when many distribution feeders may suffer transient faults.

25.5.2 Automatic Sectionalisers

An automatic sectionaliser is a switching device that detects the flow of current in excess of a set value and opens a switch to disconnect the network downstream of the device. Because such devices are usually pole-mounted, in locations remote from a suitable electricity supply, the sensing and switching mechanism is arranged to be self-powered. The expense of a transformer, etc. to provide such a supply from the supply side of the line is not justified and adds additional complication. By placing automatic sectionalisers at intervals along the line, it is possible to disconnect only the faulted section of line and those beyond it. The number of consumers affected by a permanent fault is minimised, and a more precise indication of the location is possible. For circuits that have more than one feed and a normally open point (Figure 25.7), loss of supply until the fault is repaired can be limited to the section in which the fault lies. The sectionaliser at point B opens automatically and the operator can take action to open the one at point C. The faulted section is thus isolated and (subject to system conditions being satisfactory) the sectionaliser at the normally open point may be closed.

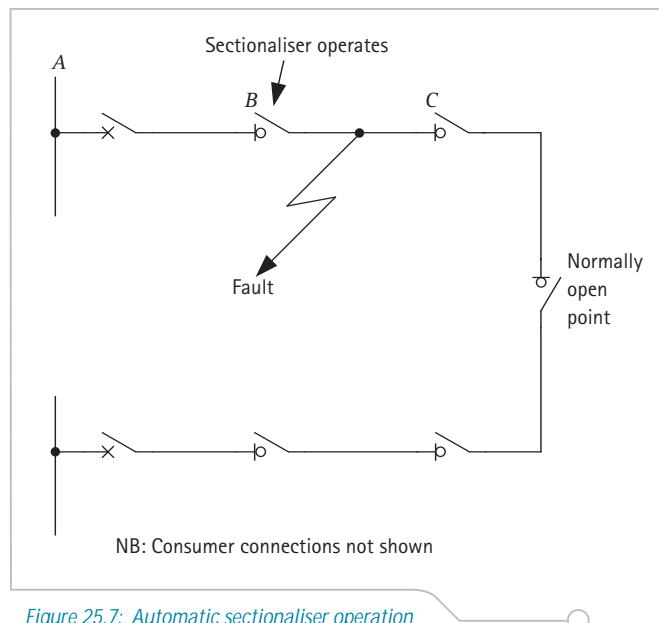

Figure 25.7: Automatic sectionaliser operation

However, there can be drawbacks as well. Grading of the feeder circuit breaker with the sectionalisers may be difficult and result in longer fault clearance times for faults in the section between the circuit breaker and first sectionaliser. The circuit breaker must be rated for the resulting fault duty. Consumers situated in healthy sections of line may suffer extended voltage dips, which may give rise to problems with equipment. An illustration of the device is given in Figure 25.8.

A development of the automatic sectionaliser is the automatic recloser. This device opens when a fault is sensed, and subsequently re-closes according to a pre-set sequence. It can be thought of as the distribution network equivalent to an auto-reclose scheme applied to circuit breakers on an EHV transmission line. It overcomes the disadvantage of a sectionaliser in that transient faults do not result in loss of supply to consumers downstream of the device.



Figure 25.8: Modern automatic sectionaliser

The first automatic reclosure operates a short time after opening and will usually be successful if the fault is a transient one. Should a fault still be detected upon the first reclosure, the recloser deliberately remains closed for a significant time to try and clear the fault by using the arc energy to burn out the cause of the fault. The recloser then opens, and closes after a pre-set dead time. Should the fault still exist, a further burn time/open/reclose cycle is carried out, after which a final open/lockout operation is performed if the fault still exists. The usual remote control and indication facilities are provided. Some form of condition monitoring may be used, so that maintenance is requested only when required, and not on the usual basis of the number of switching operations carried out. Figure 25.9 shows the distribution network of Figure 25.6 after application of full automation as described above.

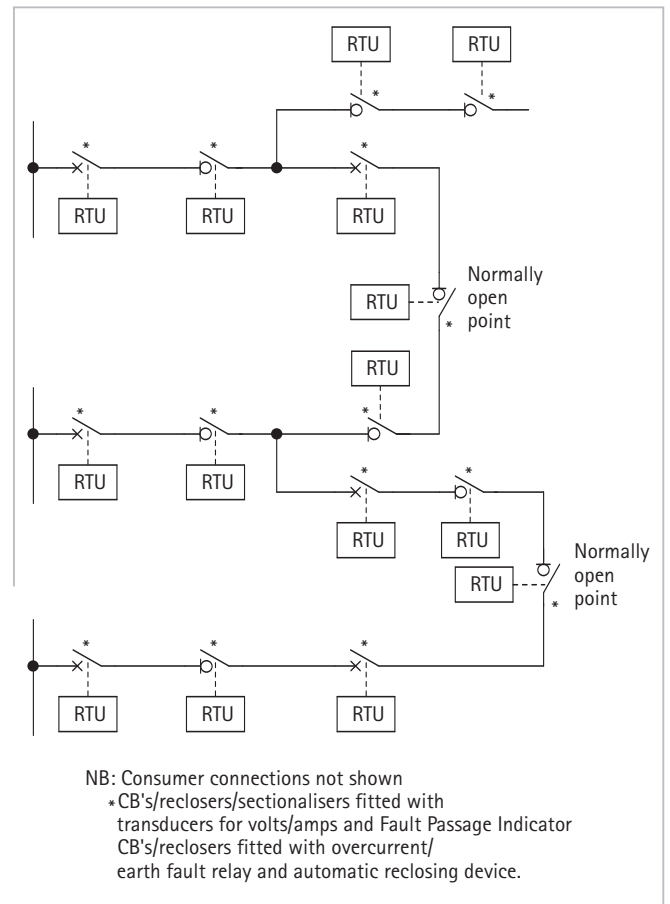

Figure 25.9: Automated rural distribution network

The benefits provided are:

- a. rapid restoration of supply to all consumers following transient faults
- b. disconnection of the minimum number of consumers following a permanent fault
- c. indication of network performance to the control centre, including fault location and network loading
- d. reduced requirement of field crews to carry out manual switching
- e. reduced fault location time

In common with other distribution systems, intelligent devices such as circuit breakers and sectionalisers fitted with remote control and current/power sensing devices can be used to gather information on network operating conditions and hence be used as inputs when network enhancement is being considered. With existing equipment, such information may not be available at all unless a field measurement exercise is undertaken. The information can be used not only to identify constraints in the network, but also to determine spare capacity much more accurately (in terms of permissible short-term overloads possible without excessive temperature rises occurring). Network re-inforcement may then possibly be postponed or even eliminated, resulting in

reduced capital expenditure requirements. There is also the potential for improved thermal modelling of plant, to produce a more accurate thermal loss-of life indication.

25.6 COMMUNICATIONS

Perhaps the most difficult task in automating a distribution network is selection of the appropriate communications technique for implementation of the remote control/reporting facilities. Several techniques are available, as follows:

- a. hard-wired
- b. Public Switched Telephone Network (PSTN)
- c. mobile radio (packet switched data)
- d. conventional or low-powered radio (including Microwave)
- e. Power Line Carrier Communication (PLCC)

Trials to date appear to indicate that the choice of communications medium is critical. Therefore, extensive investigations in this area are required. Not all of the possibilities are suitable for all types of distribution system or geographical area, and this needs to be kept in mind.

25.6.1 Hard-Wired Communication

Hard-wired communication is generally not a viable option, as the infrastructure will not be available. The costs of installing the required cabling will be large, and it will normally be found that there are less expensive solutions available. However, in cases where there is infrastructure already available, this solution will be attractive. All cabling suffers from the possibility of faults, and therefore an alternate route, maybe sourced from a telecomms provider, may be required as backup.

25.6.2 Use of PSTN Network

Use of the existing fixed public telecomms infrastructure will normally be feasible for urban distribution networks. For rural networks, the required infrastructure probably does not exist. Line quality will be of critical importance and equipment to ensure detection of errors in transmission, and request repeat transmission of data, will probably be required. Similarly, as substations are areas of high electrical interference, appropriate measures to protect the required hardware in substations will be required. Technical solutions to these problems readily exist, but appropriate data on the probable interference levels, especially those occurring transiently under fault conditions or due to lightning strikes on overhead lines are required to ensure that equipment is

properly specified. Reported experience on schemes in operation suggest that call set-up times may be slow, and line quality (even in densely populated urban areas) may not be high, leading to slow data rates and hence restrictions in the amount of data that can be transmitted in a reasonable time.

25.6.3 Mobile Radio

Mobile radio is a quite attractive option. Many companies offer packet-switched data techniques to business users. Field experience reported to date indicates that this method is well suited to both urban and rural areas. The main problem in urban areas appears to be shielding of the required antennas by other buildings or parked vehicles – a problem shared by all communications techniques involving radio. In rural areas, investment may be required to provide the necessary area of cover, and this may take time to achieve, depending on the priorities of the telecomms provider involved. However, mobile telecomms service providers are usually keen to expand service coverage and sites for the required masts may conveniently be located along the right-of-way of the distribution system lines.

25.6.4 Conventional Radio

Use of radio as a telecomms medium is well established amongst Utilities. Low powered radio has been used in a number of trial installations of distribution system automation schemes without significant problems. The requirements for base stations are similar to those for mobile telecomms, together with the same possible hazards. One possible drawback to greater adoption of such techniques is that low-powered radio is not subject to regulation in some countries. There is no guarantee that interference from systems operating on the same or nearby frequencies will not occur, nor is there any mechanism available to ensure that a frequency, once chosen, is reserved solely for the user in that area. The regulatory situation could be expected to change if wider use of such techniques occurred.

25.6.5 Microwave Transmission

Microwave transmission is a possibility, although severely handicapped by the fact that it relies on line-of-sight communications. Numerous repeater stations may therefore be required in hilly terrain. It does not appear to have been used in trials reported on to date so the practical performance cannot be judged. However, given appropriate terrain, it still merits consideration.

25.6.6 PLC Communications

Power Line Carrier is a technique that is well known to Utilities and makes extensive use of existing Utility-owned infrastructure. However, additional equipment is needed at each substation to ensure that the signal only travels along the desired path and is prevented from travelling along others and causing unwanted interference. The additional equipment required can make a new installation expensive, and retrofit on existing distribution systems at lower voltages probably prohibitively so. Space provision for the required line traps and coupling transformers is required, which may be difficult to find at many locations. At higher distribution voltage levels (e.g. 66kV/110/132kV), it is more attractive, especially as it may already have been installed for other reasons. Data rates may be limited and transmission failure may occur under fault conditions, just at the time when it is most needed.

Whichever communications medium is chosen, care is also needed in the choice of communications protocol. The common IEC 60870-5-103 master/slave protocol used by many protection/measurement devices is not wholly appropriate for such techniques. It requires polling by the master station of the slave devices on a regular basis, whereas initiation by field devices is ideally required, in order to limit the communications bandwidth required. Protocol converters may be required in the field, making one additional source of unreliability. At the Control Centre, a protocol converter will almost certainly be required, to interface to the SCADA system in use. Each element in the scheme must be reliable in operation and not be prone to false operation in any way, otherwise credibility is rapidly lost. Not only will the scheme fall rapidly into disuse, but also the experience will colour the assessment of future schemes for many years to come. More information on data transmission protocols is to be found in Chapter 24.

25.7 DISTRIBUTION SYSTEM AUTOMATION SOFTWARE TOOLS

To assist the operator of a distribution network, there are a number of software tools that can be used to assist in making decisions and implementing them. They are:

- a. topology analysis
- b. power system calculations
- c. power quality management
- d. system configuration management

The tools may be available as on-line interactive tools, to assist in decision-making, or as off-line tools to study the impact of decisions ('what-if' scenarios). Some of the technology is available now, especially in off-line form, but all features described are under active

development and can be expected to be available soon, producing further enhancements in distribution network performance.

25.7.1 Topology Analysis

In its' simplest form, topology analysis can be simply an operator display of the distribution network, using colours to differentiate between the various states in the network. The network may be displayed in terms of its' state (energised/non-energised), voltage level, or source of supply.

More advanced software tools may involve state estimation of the network, using historical or assumed data. This is used to fill in gaps in the known network topology, due perhaps to communications failures or use of legacy equipment without communications facilities on some parts of the network. The results of the analyses are displayed and are used as inputs to other software tools.

25.7.2 Power System Calculations

These involve load flow and fault level calculations to determine network loading, possible overloads on equipment and to ensure equipment is operated within fault level ratings. Special requirements may exist in implementing solution techniques due to the radial nature of the network. It may also be necessary to predict network performance in the future by assuming loads, or to assume data where it is lacking, by use of state estimation techniques. The losses in the distribution system, or any part of it, can be evaluated to determine the efficiency of the network and as an input to intelligent configuration tools to assist the operator in selecting the most appropriate configuration as network conditions change.

25.7.3 Power Quality Management

Power Quality has been covered in Chapter 23. Software can be used for calculating various performance indices relating to Power Quality. The results, whether obtained off-line or in real-time, can be used to influence the operation of the network to minimise either one or several of the performance indicators. There may be economic benefits for the Utility through more efficient use of the network and avoidance of financial penalties where performance targets are not met. The tool will use inputs from the Topology Analysis and Power System Calculation tools in order for the functions to be carried out. Typical user outputs are tap changer and capacitor switching schedules, energy losses for the whole or selected parts of the network for defined periods of time, harmonic levels, data relating to supply interruptions

(Customer Minutes Lost, etc), and reliability indices for the network. The data relating to losses can be split into those that are load related and those that are independent of load. This data can be input into tools relating to Asset Management, as the choice of feeder type/rating and design of transformers, etc. can be influenced by such factors.

25.7.4 System Configuration Tool

This tools can be used either off-line to examine the impact of proposed changes to the network, or on-line to suggest changes to a network to yield optimal results, according to a number of user-specified criteria. The impact of proposed switching sequences is also analysed, to ensure that the duty imposed is within rating. The user-specified criteria may include those relating to Power Quality, while required inputs are the outputs from the Topology and Power System Calculation tools. A further function of this tool is to calculate the optimal order of switching in a network to restore supplies after an incident, while maintaining safety. Alternative sequences that can be adopted in the event of failure of a device to respond to a command are also available.